



ROOF MOUNTED
EQUIPMENT

PRODUCT CATALOGUE

The Gentili range of roof mounted equipment for light commercial vehicles



*Gentili have been supporting van users for 40 years, providing our customers with **solutions** which are both innovative and of the highest quality.*

*Our new **roof mounted equipment range** is now even more complete than ever, and our offering includes improved performance and advanced technical design, which means Gentili can deliver products with unparalleled safety records and ease of use for operators.*

***This is our company mission:
to look above and design
THE FUTURE.***

Ernesto Gentili
Chairman



G2000 Harrier

4



The G2000 Harrier is our flagship product, having been awarded the coveted and prestigious Adi Design Index award by the Association for Industrial design, a leading Italian design and industry competition, recognised throughout the world for its robust and stringent judging.

G2000 Maxi

10

G2000 HARRIER

Loading and unloading of ladders is easier and more risk-free than ever with the G2000 Harrier, minimising health and safety issues.



G2000 HARRIER
Created in Italy by Gentili

Gentili have been supplying customers world-wide with the G2000 – a product range which has gained a reputation for its robustness and quality since its launch over 25 years ago, when the first hydraulic ladder rack for LCVs was designed and launched by Gentili.

As an ISO 9001 company, Gentili have a firm commitment to continuous improvement. The G2000 has been constantly updated and our new G2000 Harrier is the most recent dynamic enhancement to the product.

As with all the G2000 products gone before, the Harrier is designed and manufactured in Italy and brings together the wealth of knowledge and time-served experience Gentili have in this market.

The G2000 Harrier is designed to utilise the original roof mounting points. The design improvements bring together quality and style with a touch of Italian flair.

Why fit anything else?

Fit the best, fit the original.

DESIGNED WITH ERGONOMICS IN MIND

The G2000 Harrier offers a fully assisted ladder mounting and deploying system, therefore becoming the ideal partner for customers looking to equip their vehicles with a safe and easy to use solution.

Due to its design, the G2000 Harrier offers an easy glide, single person operation. All actions are carried out by the operator with their feet on terra firma at all times, being equipped with a precision engineered hydraulic system.

Through 25 years of active use and continual improvement the G2000 Harrier is the most advanced and safest system of its type available.



MAXIMUM FLEXIBILITY

The G2000 Harrier will carry most ladder types available on the market.



The new version of the G2000 Harrier has added features to further improve the safe transport of ladders when the vehicle is moving.

The two retainer loops can be moved forwards and backwards independently, to suit different ladder lengths, to keep the ladder in the correct position in relation to the vehicle roof. They are

covered with hard wearing rubber, to protect them from the abrasion caused by the ladder rungs.

The front and rear bearers have adjustable, impact resistant ABS plastic side retainers, to contain the ladder laterally when the vehicle is moving.



MAXI

G2000 Created in Italy by Gentili

*The **G2000 Maxi** is the latest addition to our ladder rack range, designed and manufactured at our state of the art facility in Italy. This new product has been designed to securely store two ladders at the same time, whilst still offering the same operational smoothness and safety as our G2000 Harrier single ladder rack.*



Two ladders can be mounted side by side. Two adjustable ladder retainers ensure that the ladders are held in place during transit. Securing straps hold the ladders firmly against the ladder rack at all times.



Sideways movement of the ladders being carried is stopped by the adjustable pair of load stops, fitted front and rear.



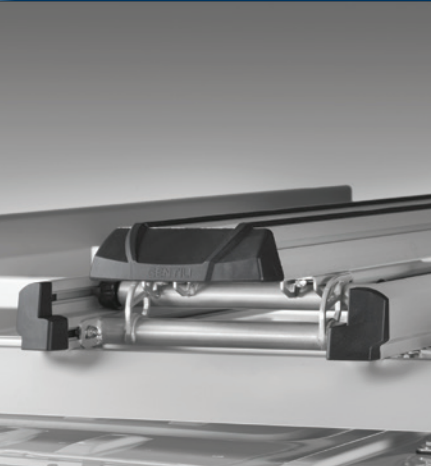

LIGHTWEIGHT DESIGN

main structural parts made from anodised aluminium.



UNIVERSAL INSTALLATION

the system can be fitted onto any light commercial vehicle on the market.

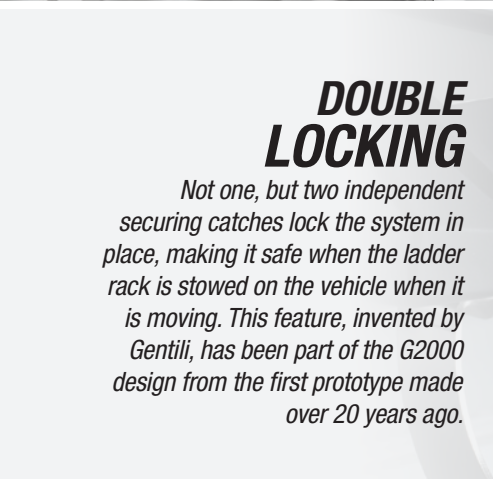

DOUBLE LOCKING

Not one, but two independent securing catches lock the system in place, making it safe when the ladder rack is stowed on the vehicle when it is moving. This feature, invented by Gentili, has been part of the G2000 design from the first prototype made over 20 years ago.



DURABLE MATERIALS

main parts made from anodised aluminium, offering maximum protection from corrosion and allowing for minimal maintenance. Stainless steel parts offer strength and extended longevity.



IMPROVED AERODYNAMICS

New profile parts are designed to be safe, strong and low profile; reducing both wind noise and reducing impact on fuel consumption.



NEW DESIGN

the new design offers improvements to quality and style.



SECURE

new profile parts are designed to be safe, strong and low profile; reducing both wind noise and reducing impact on fuel consumption.

TÜV GS CRASH TEST

Gentili take safety seriously – and don't just take our word for it; the G2000 range is TÜV tested and certified and has been crash tested to a 20g force on a vehicle shell. When we say it is safe, we mean it.



TECHNICAL SPECIFICATIONS

	LB G2000 Harrier	LB G2000 MAXI
Type 1 ladder rack	86	92
Type 2 ladder rack	90	105
Type 3 ladder rack	99	110
Type 4 ladder rack	106	117

Safe maximum carrying weight 132 LB
TÜV GS certified
20g Crash tested according to ECE R17

• G2000 Harrier Ladder rack Dimensions: IN

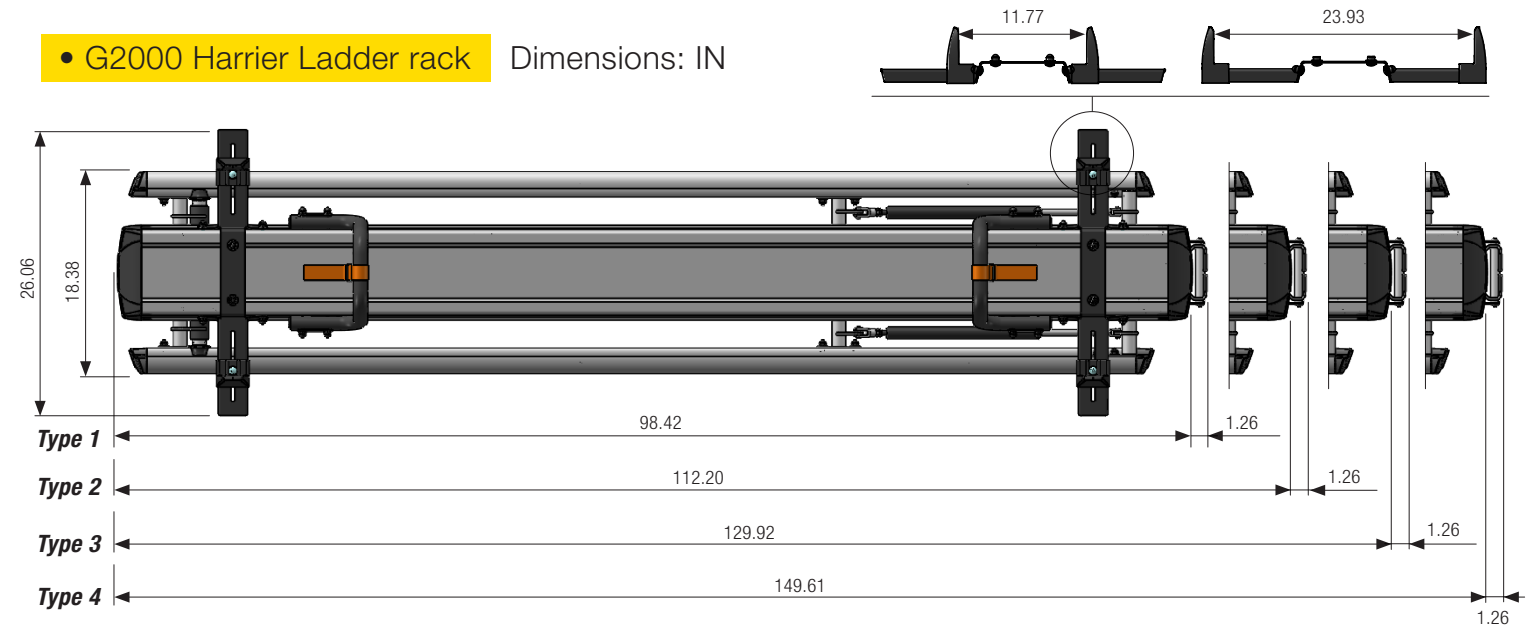

• G2000 MAXI Ladder rack Dimensions: IN

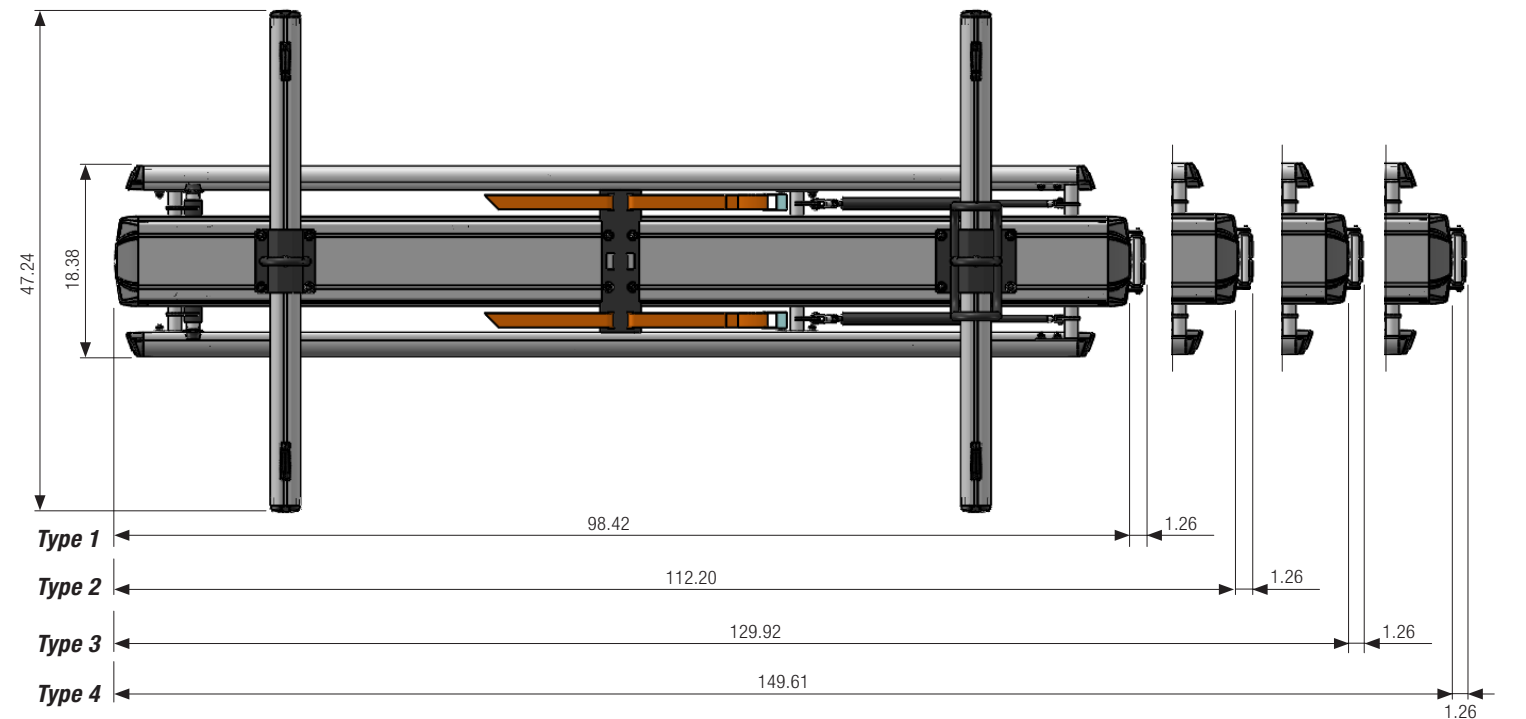



Gentili United States, Inc.
100 S.E. 2nd Street
Miami, FL 33131 - USA
Tel. +001 603-326-4269
gentili@gentili.us.com

www.gentili.us.com